



TOYOTA Technical Service BULLETIN

May 7, 2007

Title:

WINDSHIELD WIND NOISE

Models:

'05 Tacoma

T S B

NV/006-07

H/V/H

Introduction Some customers may experience a wind noise that sounds like a “buzz” or “reed vibration” sound from the windshield area. This condition may be the result of wind (air) pressure creating rapid oscillations of the rubber windshield molding, which produces a high-pitched buzzing or whistling sound.



The following repair information will assist in the repair of this condition.

- Applicable Vehicles**
- **2005** model year **Tacoma** vehicles.

Required Tools & Material

TOOLS & MATERIAL	PART NUMBER	QUANTITY
3M™ Clear Auto Glass Sealer	08551	1
3M™ General Purpose Adhesive Cleaner	08984 (Liquid) 08987 (Spray)	1
2” Wide Masking Tape	–	As needed

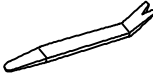
Required SSTs

ITEM NO.	SPECIAL SERVICE TOOLS (SSTs)	PART NUMBER	QTY	DRW**
1	Plastic Pry Tool Set*	00002-06000-01	1	20
COMPONENT(S) OF KIT/SET	NOTE: • All components from this kit/set are required.			
	<ul style="list-style-type: none"> • Plastic Panel Clip Removal Tool (P/N 00002-06001-01) • Plastic Emblem Removal Tool (P/N 00002-06002-01)  			

Warranty Information

OP CODE	DESCRIPTION	TIME	OFF	T1	T2
NV7008	Reseal Windshield Molding	0.7	56101-04010	91	14

Applicable Warranty*:

This repair is covered under the Toyota Comprehensive Warranty. This warranty is in effect for 36 months or 36,000 miles, whichever occurs first, from the vehicle's in-service date.

* Warranty application is limited to correction of a problem based upon a customer's specific complaint.



Diagnosis Procedure

The purpose of this procedure is to determine if the rubber windshield molding is lifting away from the body at highway speeds.

1. Apply 2" wide masking tape over the rubber windshield molding where it meets the body up both A-pillar and the roof (bridge over the edge of the molding where it lays against the A-pillar and the roof). Refer to the illustration below.

NOTE:

Do NOT add tape between the rubber molding and the windshield glass.

2. Once the masking tape is in place, test drive the vehicle at highway speeds (above 50 mph [80 km/h]), by traveling in both directions on the highway (to compensate for any crosswinds).
 - If the tape application between the molding and the body eliminates the noise, proceed to the "Repair Procedure" section in this TSB.
 - If the noise is still present, apply tape to seal additional components until the source location of the noise is identified.

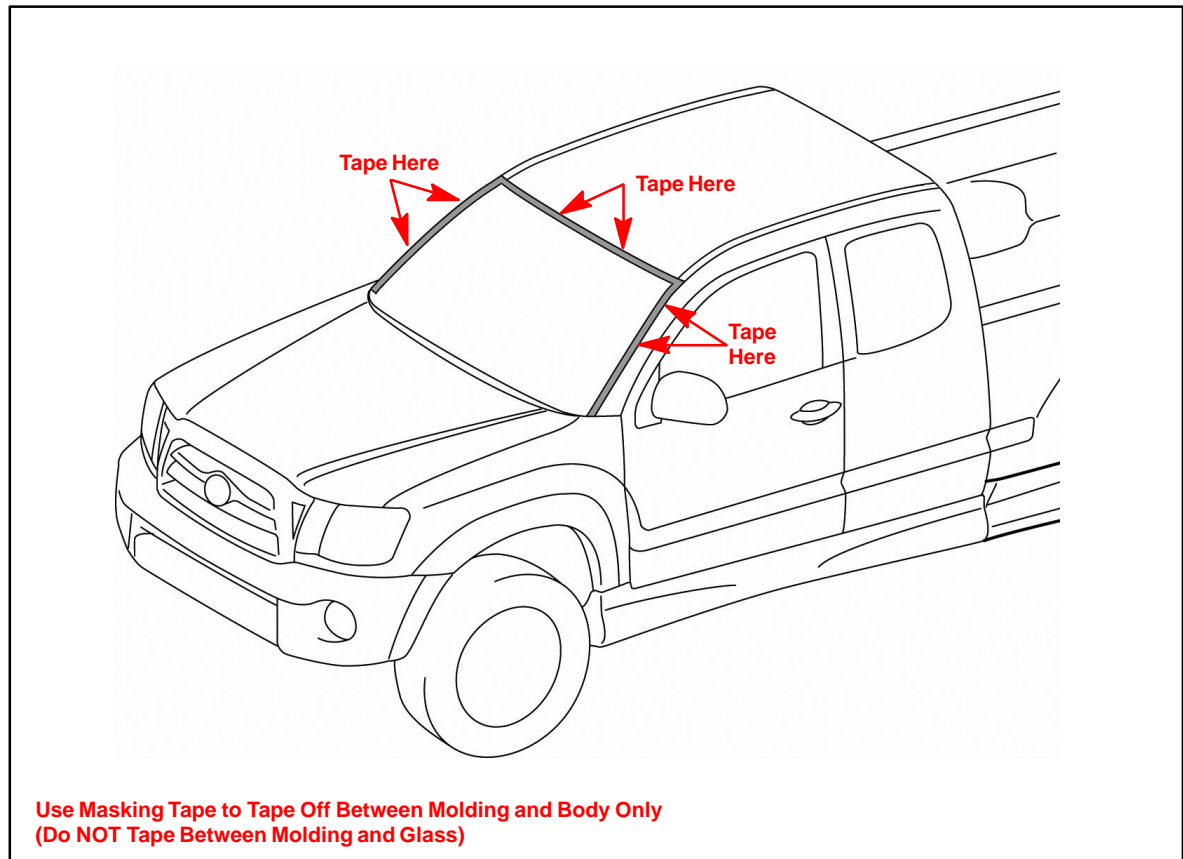

**Repair
Procedure**

1. While slowly sliding the pry tool up the A-pillar, follow the pry tool with the nozzle of the sealer to make a continuous bead of sealer under the rubber molding.

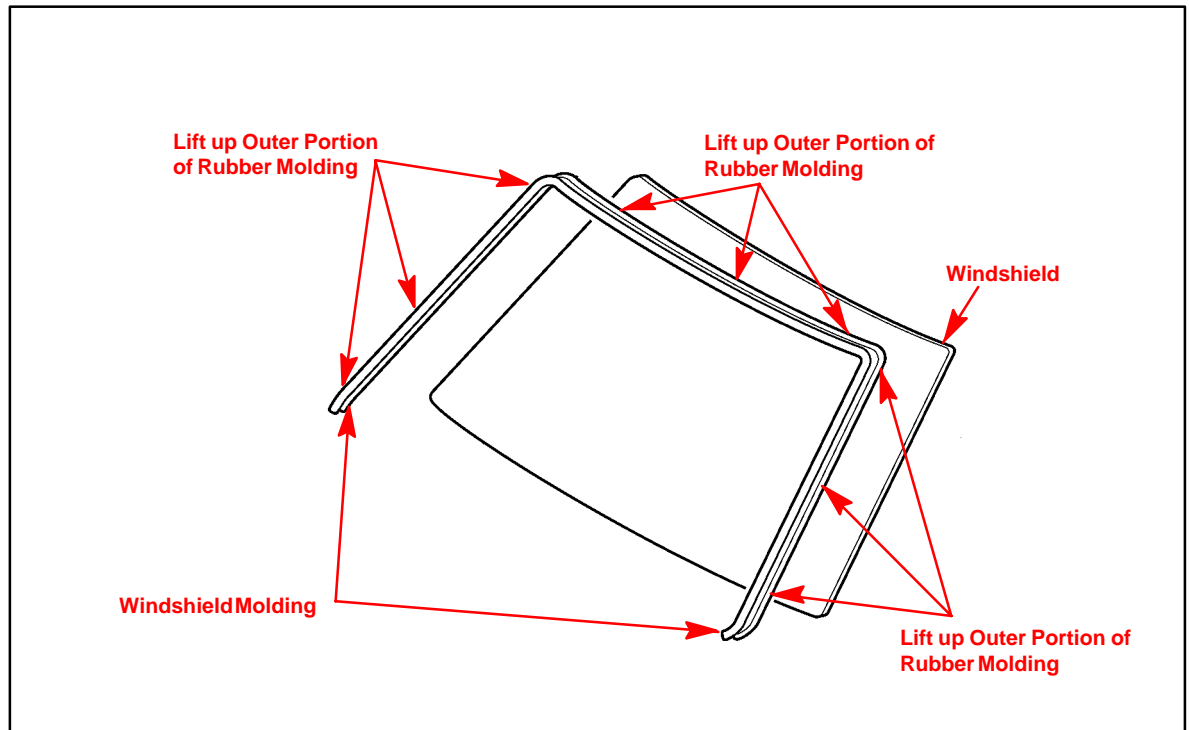

2. Continue the process up the A-pillar, across the roof, and down the opposite A-pillar.
3. Wipe off any excess sealer using 3M™ General Purpose Adhesive Cleaner (3M™ P/N 08984 or 08987).
4. Allow sealer to dry at LEAST 3 hours.
5. Test drive vehicle to confirm effectiveness of the repair.